

03.06.15

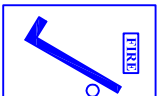

ARROW ARCHITECTURAL
Tything Road
Alcester
B496ES
15

1121-CPR-AE0006
4831113
4831113
EN1154:1996 + A1:2002
EN1155:1997 + A1:2002/AC:2006



THE CLOSER AND EAR BRACKET MUST
BE LEVEL (USE A SPIRIT LEVEL)
TO ENSURE THEY RUN PARALLEL.

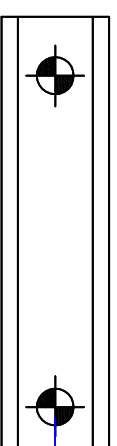

25

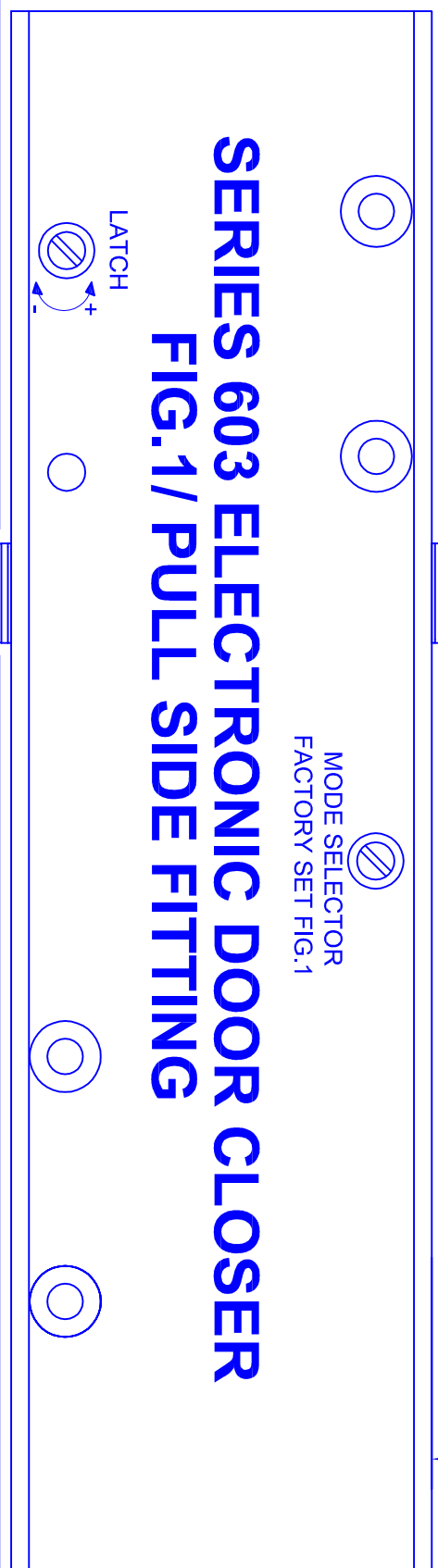
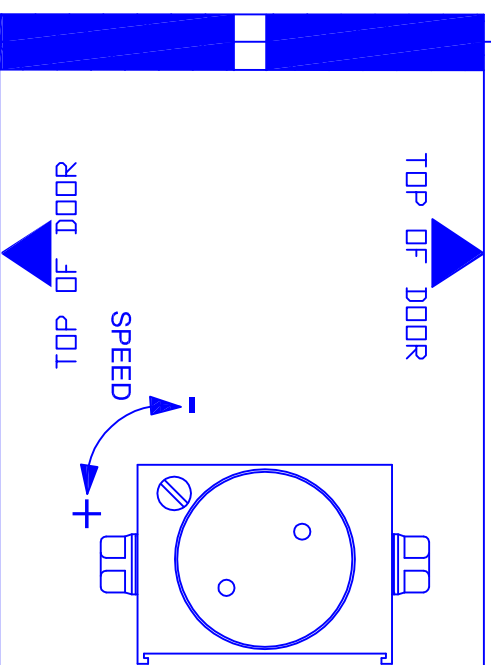
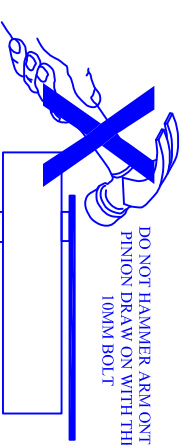

Max leaf width 950mm, Max kg 60, power 3 max opening 180°

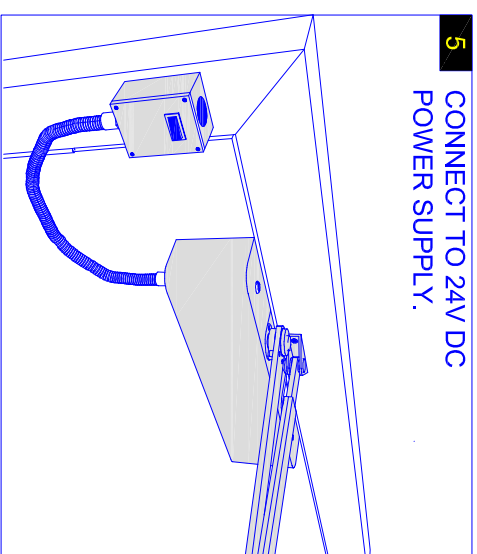
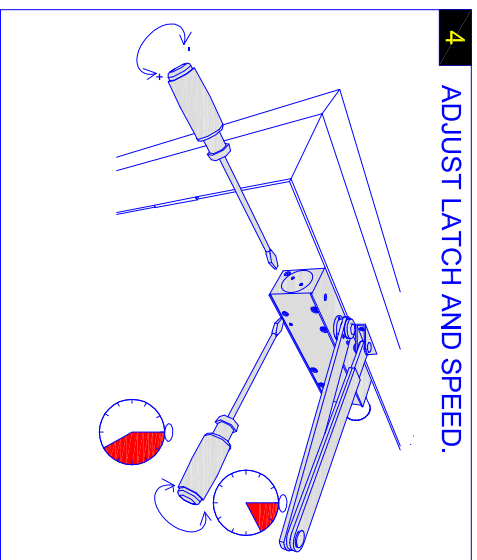
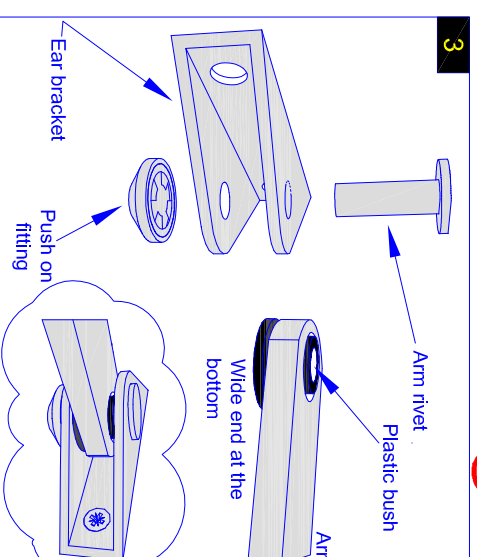
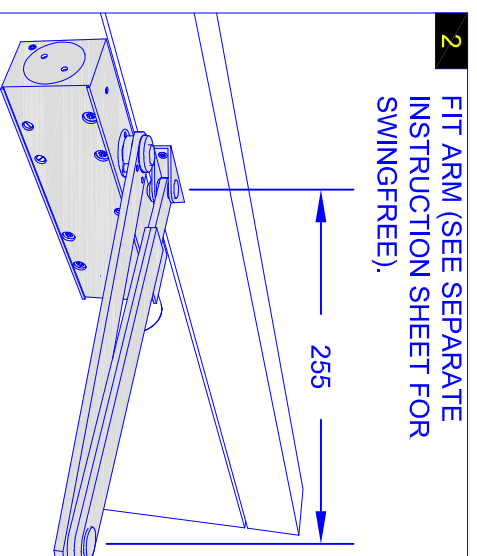
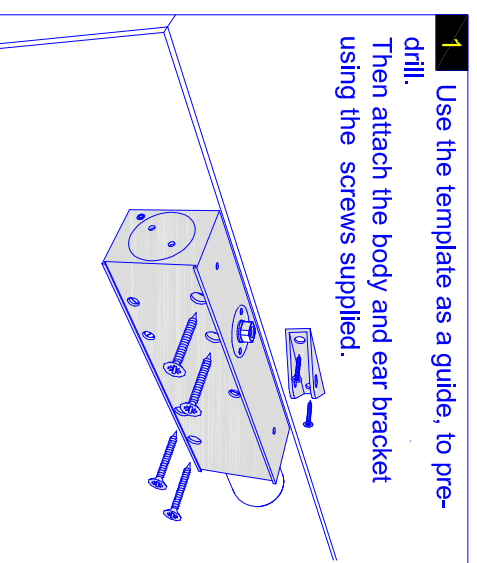
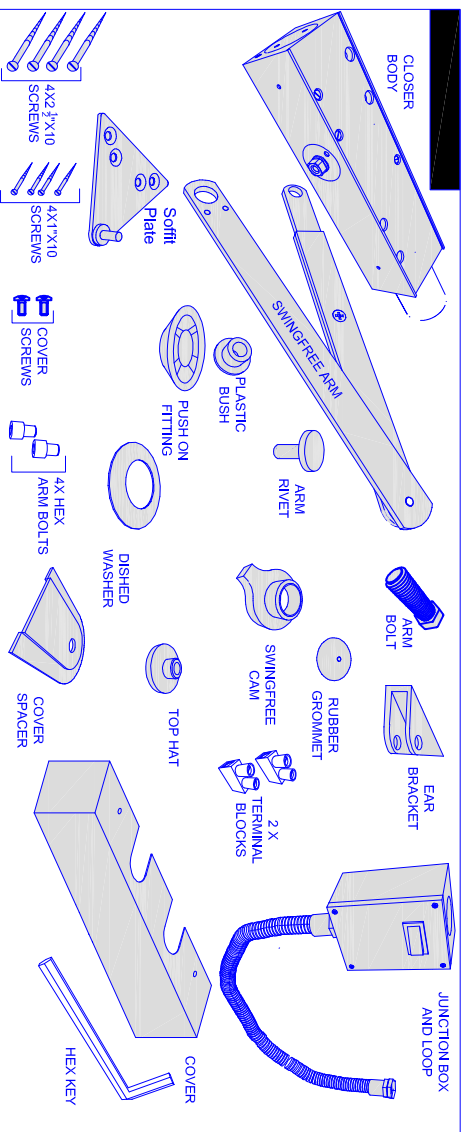
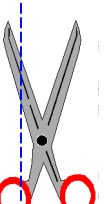
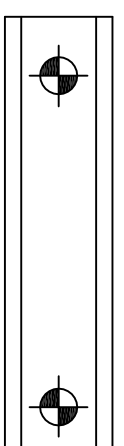

POWER REQUIRED:-24V DC-2 WATTS-0.085AMPS

WIRING INSTRUCTIONS

1. Screw the junction box onto the door frame at approximately the same height as the closer body.
2. Holding the cover, carefully thread the 2 red wires through the hole nearest to the door hinge and secure the armoured loop with the nut supplied.
3. Attach the 2 red wires from the junction box (the wires you have just put through the cover) to the 2 red wires coming out of the coil at the rear end of the closer body. (polarity is not important)
4. Connect your 24v dc supply to the switched junction box.
5. Switch the supply on and test(note:- make sure the switch on the junction box is in the on position before testing.)

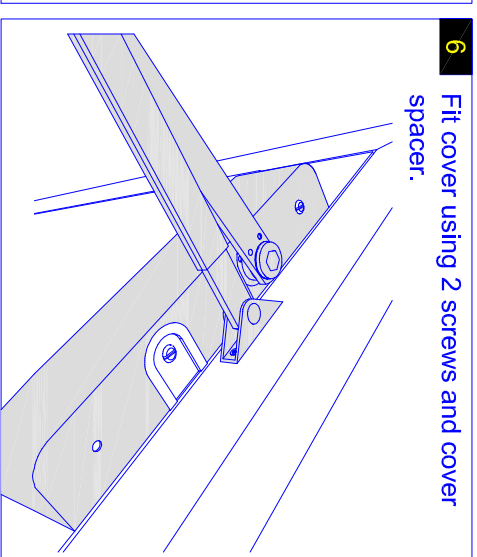

MAINTENANCE

Periodically apply light oil to the arm knuckle joint and check all screws and the pinion bolt are tight. D.O.P download available at www.arrow-architectural.com

03.06.15



ARROW ARCHITECTURAL
Tything Road
Alcester
B496ES



1121-CFR-AE0006	EN1154:1996 + A1:2002/AC:2006
3841113	EN1156:1997 + A1:2002/AC:2006
3841113	

APPROVED PRODUCT
CF 498

THE CLOSER AND EAR BRACKET
MUST BE LEVEL(USE A SPIRIT
LEVEL) TO ENSURE THEY RUN PARALLEL.

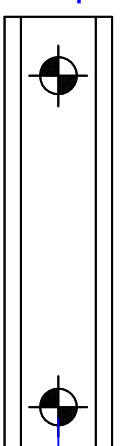

25

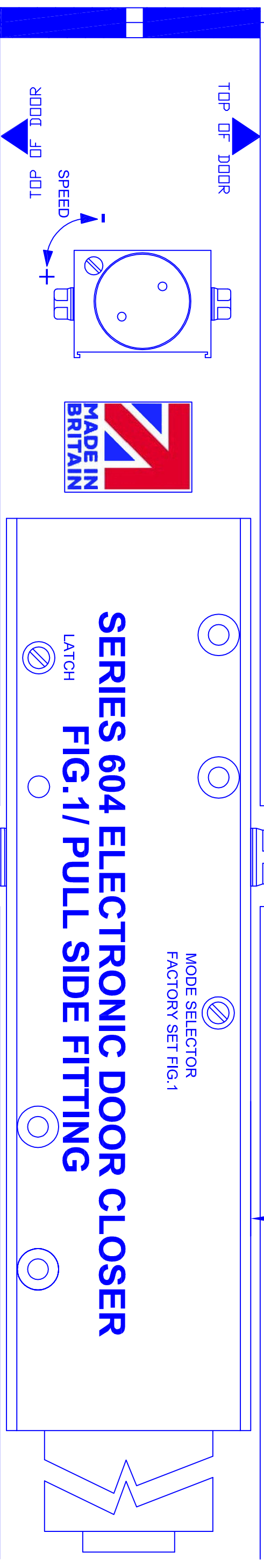
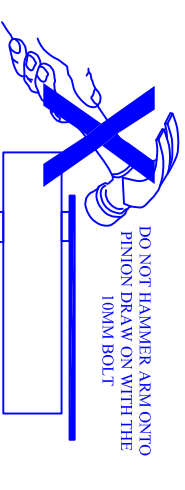

Max leaf width 1100mm, Max kg 80, power 4 max opening 110°

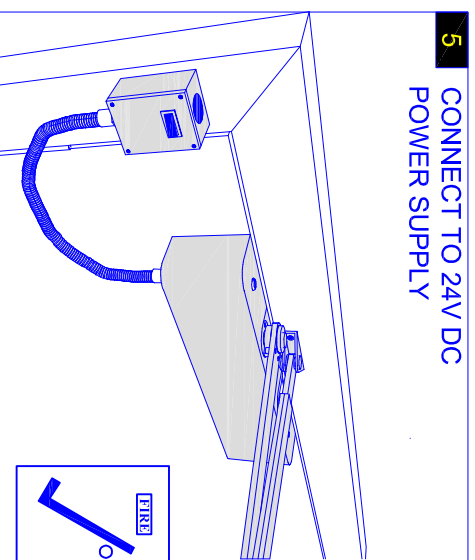
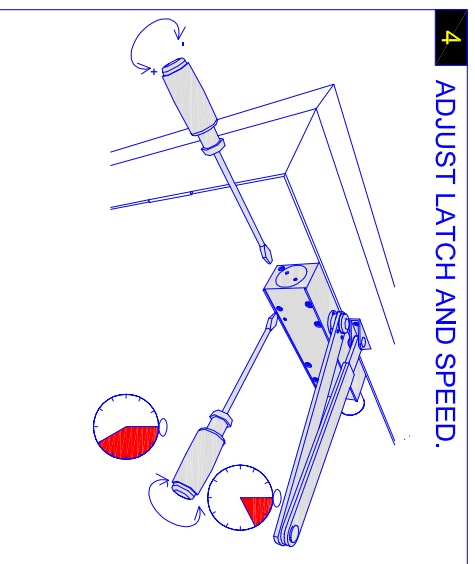
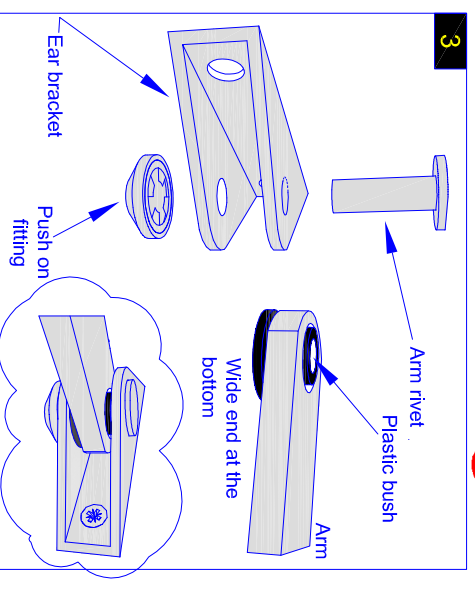
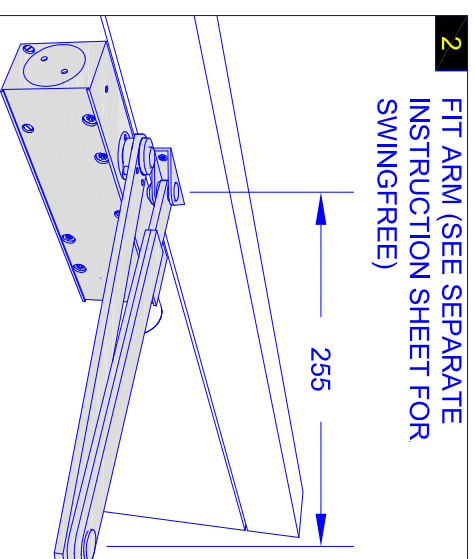
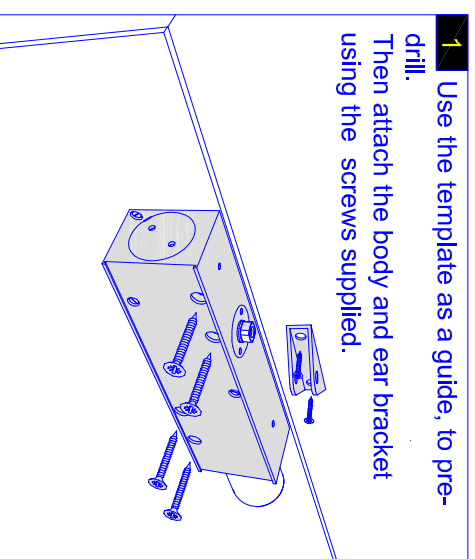
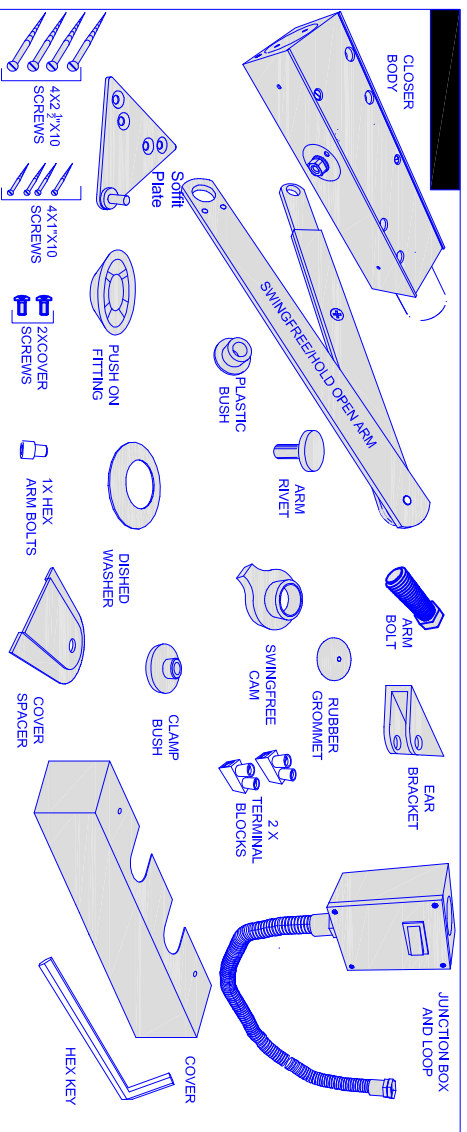
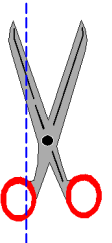

POWER REQUIRED: 24V DC 2 WATTS 0.085AMPS

Fit cover using 2 screws and cover spacer.

- WIRING INSTRUCTIONS**
1. Screw the junction box onto the door frame at approximately the same height as the closer body.
 2. Holding the cover, carefully thread the 2 red wires through the hole nearest to the door hinge and secure the armoured loop with the nut supplied.
 3. Attach the 2 red wires from the junction box (the wires you have just put through the cover) to the 2 red wires coming out of the coil at the rear end of the closer body. (polarity is not important)
 4. Connect your 24v dc supply to the switched junction box.
 5. Switch the supply on and test(note:- make sure the switch on the junction box is in the on position before testing.)

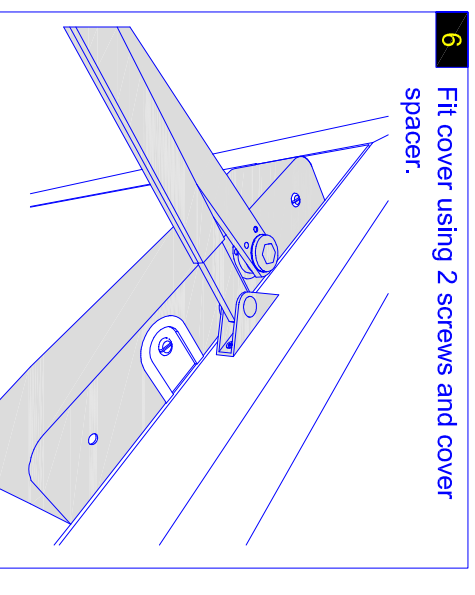

MAINTENANCE

Periodically apply light oil to the arm knuckle joint and check all screws and the pinion bolt are tight.
D.O.P download available at www.arrow-architectural.com

03.06.15



ARROW ARCHITECTURAL		15
Tything Road Alcester B496ES		
1121-OPR-AE5007	EN1154:1996 + A1:2002/AC:2006	
3851113	EN1155:1997 + A1:2002/AC:2006	
3851113		

THE CLOSER AND EAR BRACKET MUST BE LEVEL(USE A SPIRIT LEVEL) TO ENSURE THEY RUN PARALLEL.

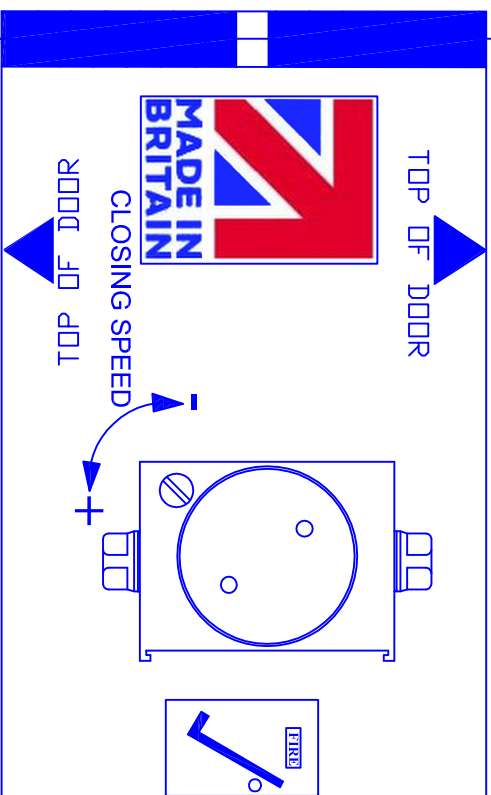
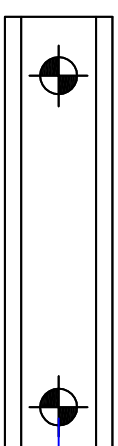

ENGINH DNWH THGIR 190 255

Max leaf width 1250mm, Max kg 100, power 5 max opening 110'

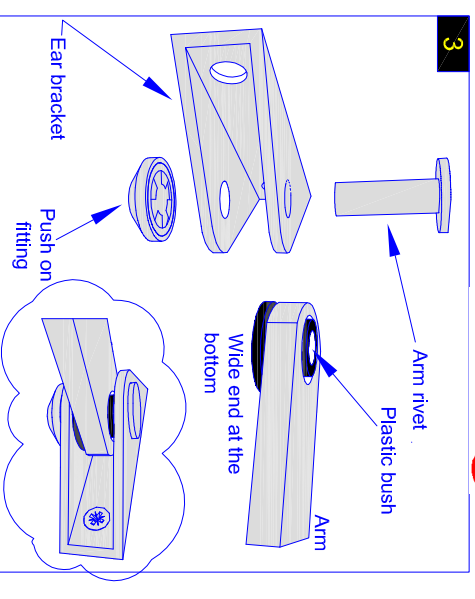
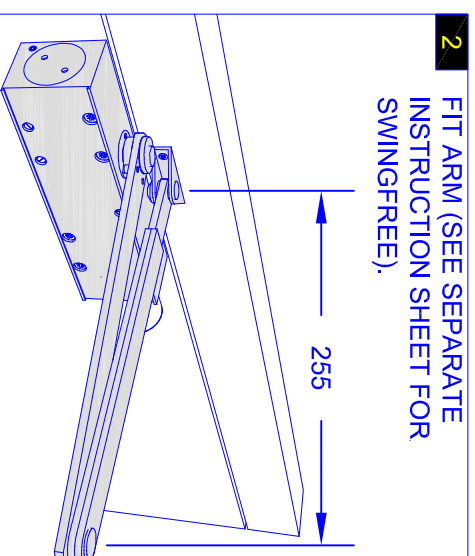
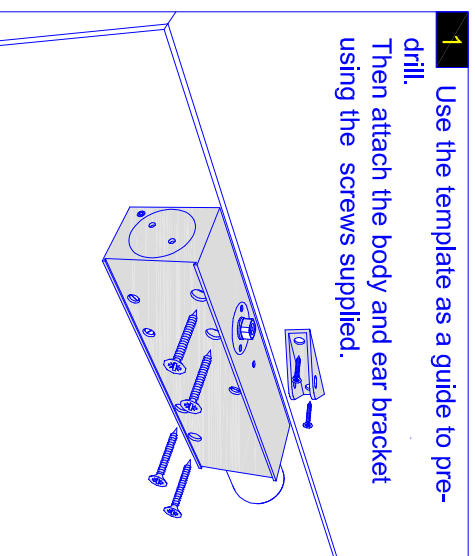
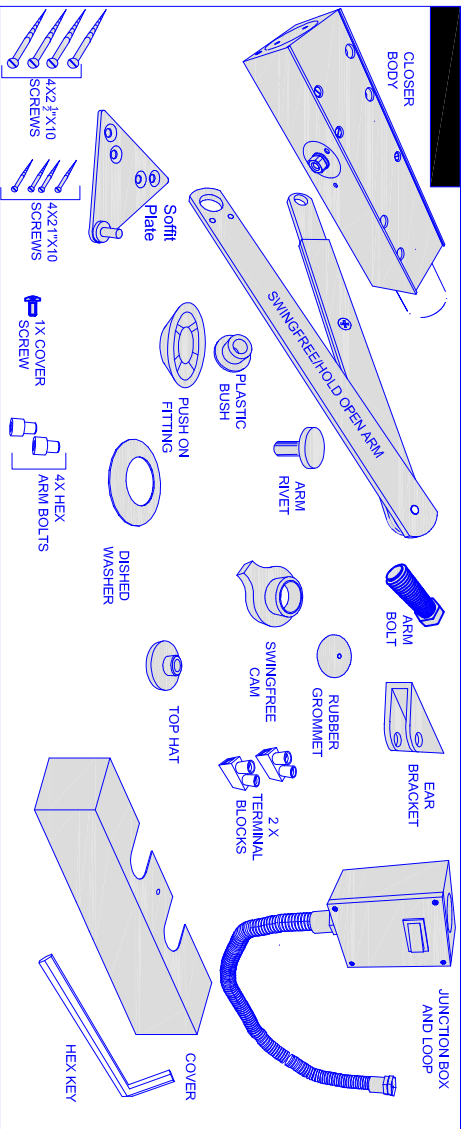
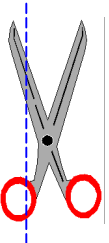
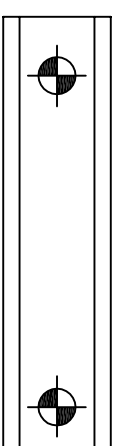

4 ADJUST LATCH AND SPEED.

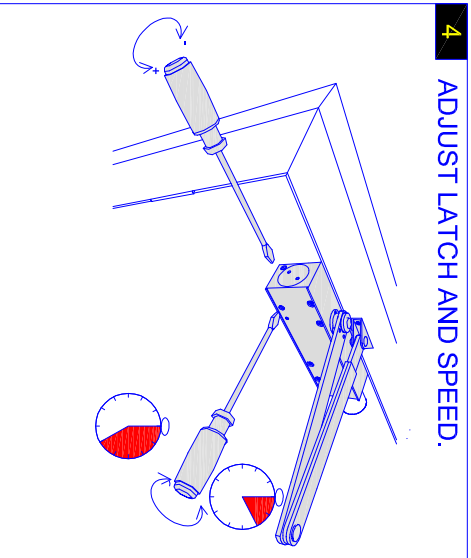

5 CONNECT TO 24V DC POWER SUPPLY.

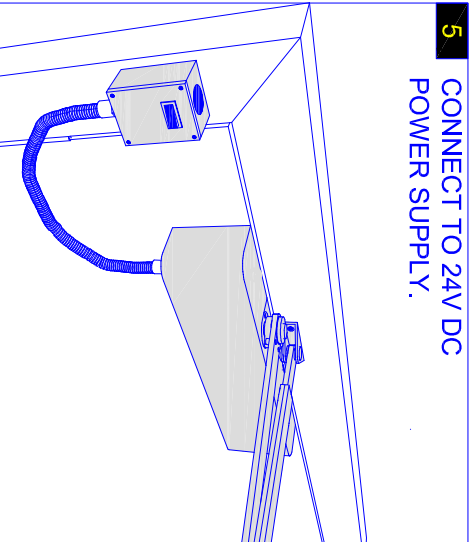

POWER REQUIRED: 24V DC 2 WATTS 0.085AMPS

6 Fit cover using 1 screw

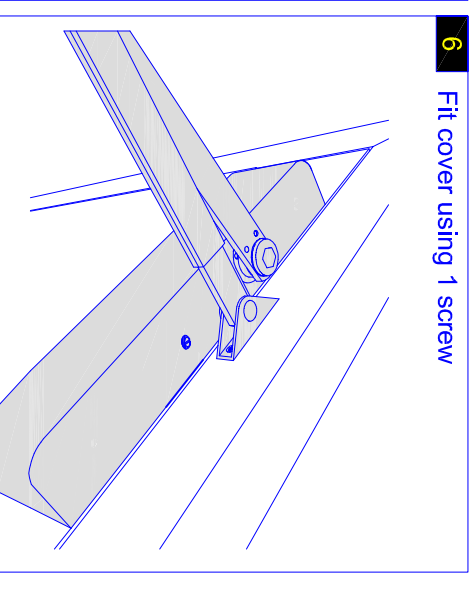

- WIRING INSTRUCTIONS**
1. Screw the junction box onto the door frame at approximately the same height as the closer body.
 2. Holding the cover, carefully thread the 2 red wires through the hole nearest to the door hinge and secure the armoured loop with the nut supplied.
 3. Attach the 2 red wires from the junction box (the wires you have just put through the cover) to the 2 red wires coming out of the coil at the rear end of the closer body. (polarity is not important)
 4. Connect your 24v dc supply to the switched junction box.
 5. Switch the supply on and test(note:- make sure the switch on the junction box is in the on position before testing.)

MAINTENANCE

Periodically apply light oil to the arm knuckle joint and check all screws and the pinion bolt are tight. D.O.P download available at www.arrow-architectural.com

03.06.15



ARROW ARCHITECTURAL	
Tything Road	
Alcester	
B496ES	
15	
1121-CPRAE007	EN1154:1996 + A1:2002
3861113	EN1155:1997 + A1:2002/AC:2006

THE CLOSER AND EAR BRACKET MUST BE LEVEL(USE A SPIRIT LEVEL) TO ENSURE THEY RUN PARALLEL.

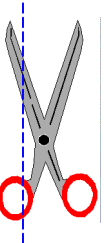
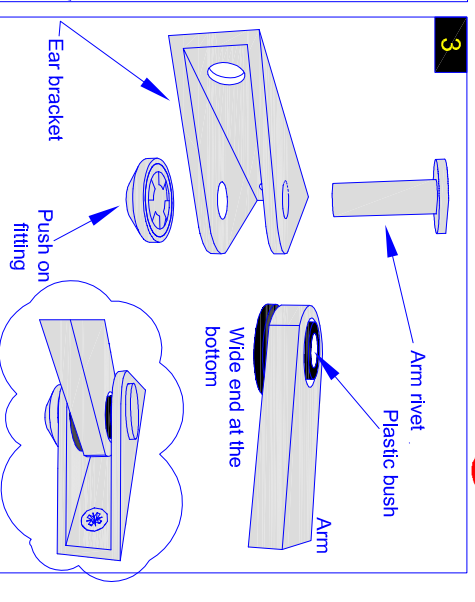
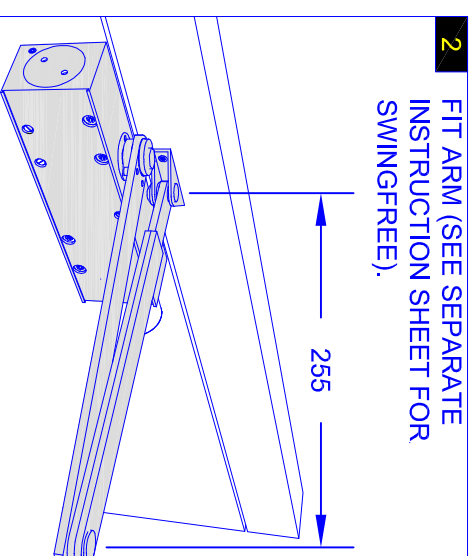
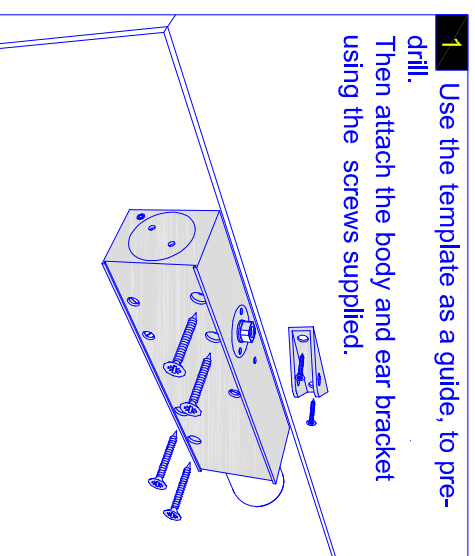
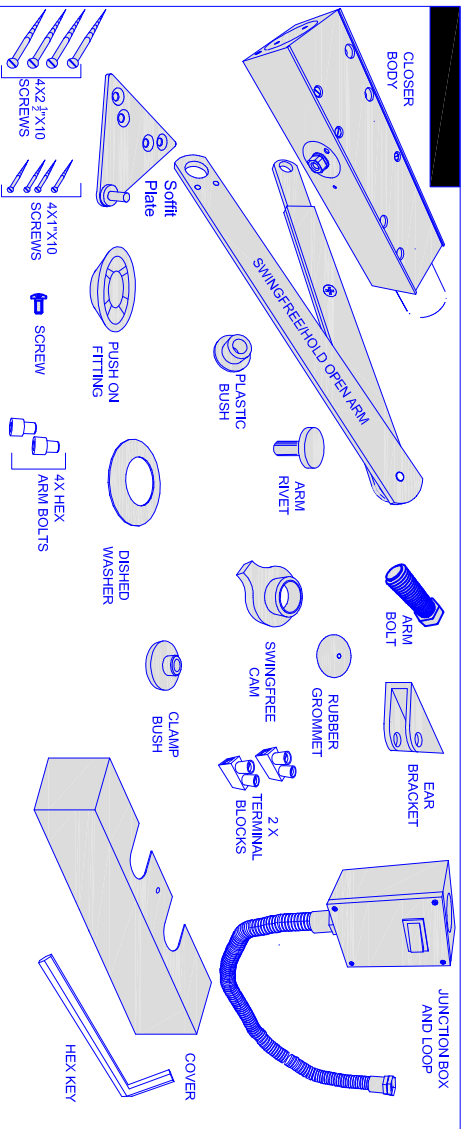
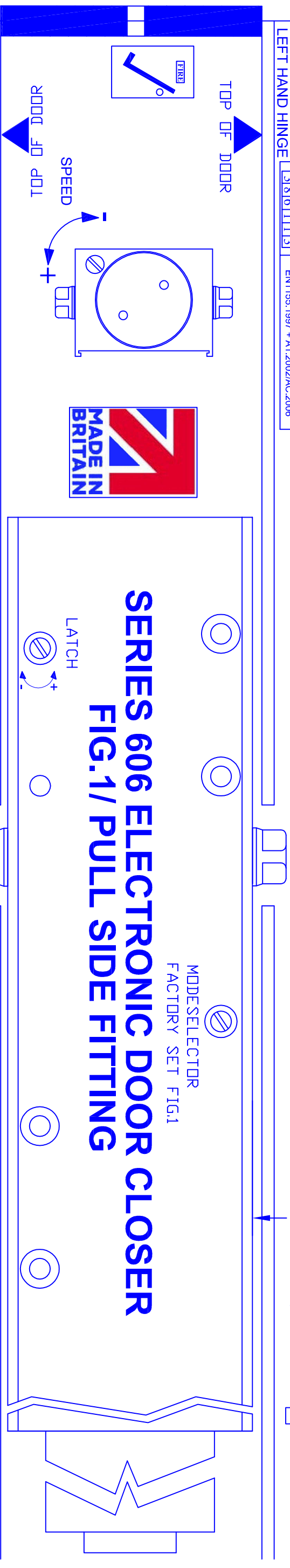
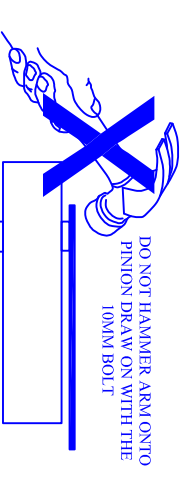
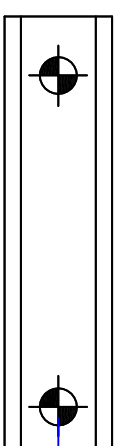

4 ADJUST LATCH AND SPEED.

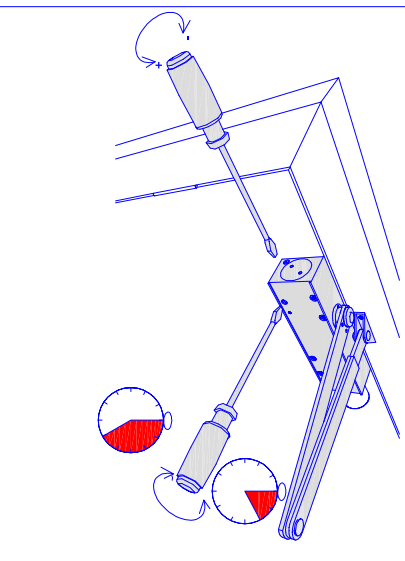

5 CONNECT TO 24V DC POWER SUPPLY.

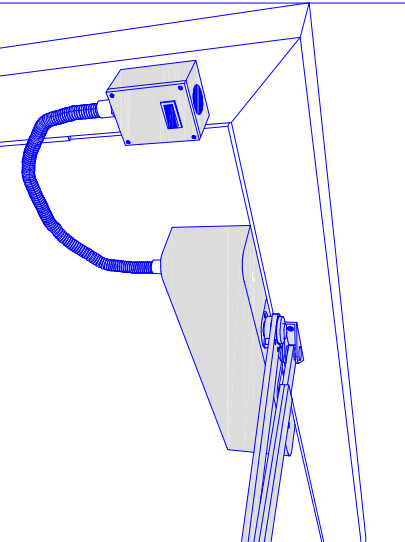

POWER REQUIRED:-24V DC-2 WATTS-0.085AMPS

WIRING INSTRUCTIONS

1. Screw the junction box onto the door frame at approximately the same height as the closer body.
2. Holding the cover, carefully thread the 2 red wires through the hole nearest to the door hinge and secure the armoured loop with the nut supplied.
3. Attach the 2 red wires from the junction box (the wires you have just put through the cover) to the 2 red wires coming out of the coil at the rear end of the closer body. (polarity is not important)
4. Connect your 24v dc supply to the switched junction box.
5. Switch the supply on and test(note:- make sure the switch on the junction box is in the on position before testing.)

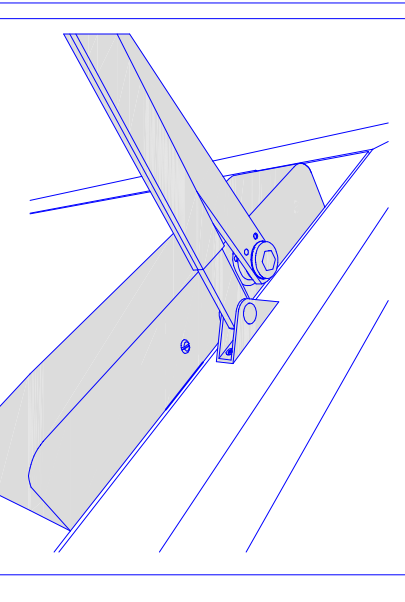

MAINTENANCE

Periodically apply light oil to the arm knuckle joint and check all screws and the pinion bolt are tight. D.O.P download available at www.arrow-architectural.com



ARROW ARCHITECTURAL
Tything Road
Alcester
B496ES



THE CLOSER AND SOFFIT PLATE MUST BE LEVEL (USE A SPIRIT LEVEL)
TO ENSURE THEY RUN PARALLEL.

1121-OPRAE0006	EN1154:1996 + A1:2002/AC:2006
3831113	EN1155:1997 + A1:2002/AC:2006
3831113	

APPROVED PRODUCT
CF 498

Max leaf width 950mm, Max kg 60, power 3, Max opening 170°

LEFT HAND HINGE

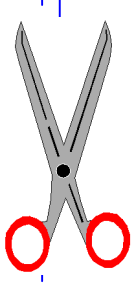
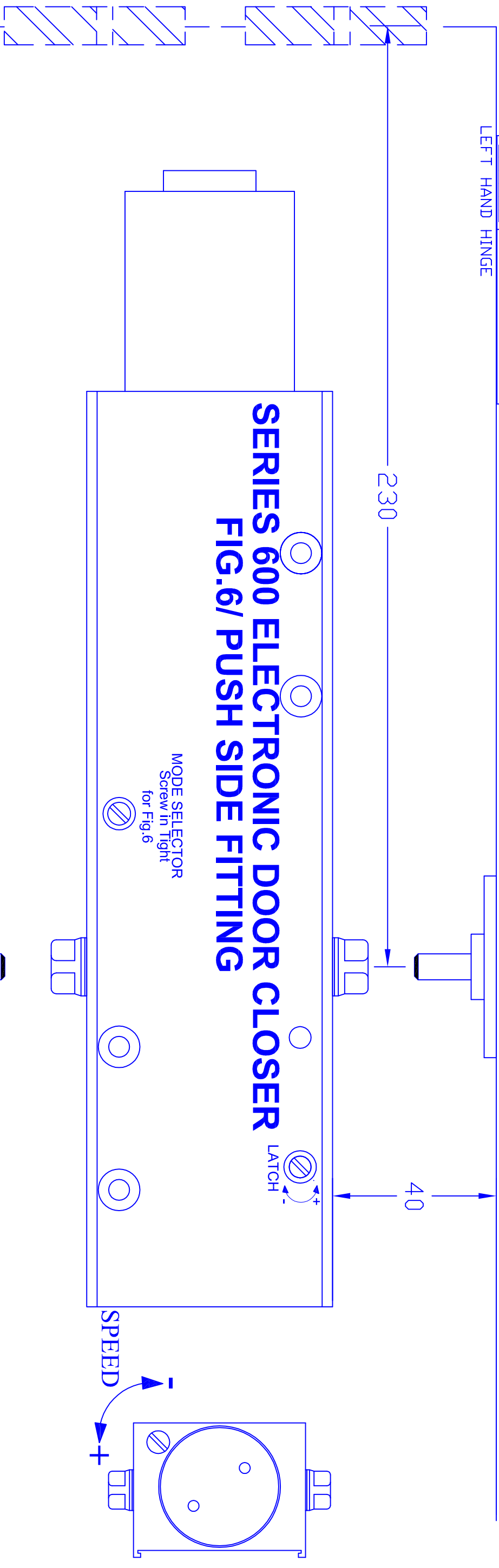
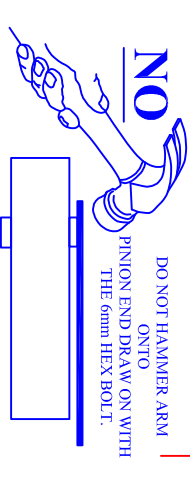

ENGINE DRAWN THGIR

1

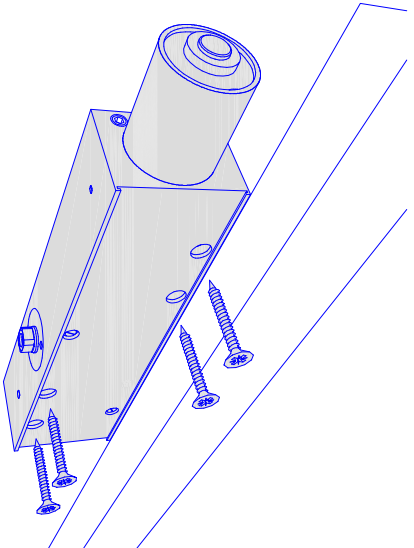

1. Use the template as a guide, drill pilot holes and screw the body to the door with the 2 1/2" wood screws supplied.

2

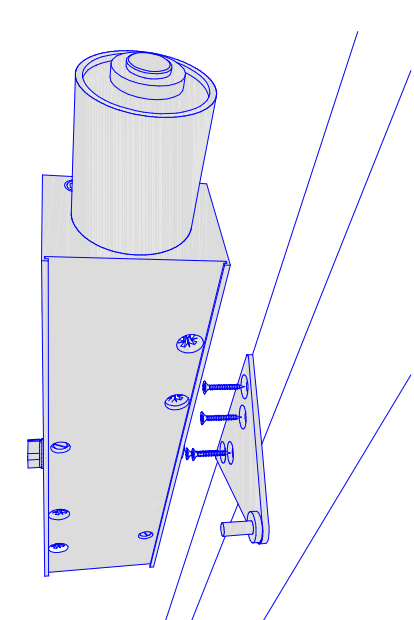

2. Use the template as a guide, drill pilot holes and screw the soffit plate to the under side of the door frame (as shown in the diagram) with the 1" wood screws supplied. The soffit plate must be against the door face.

3

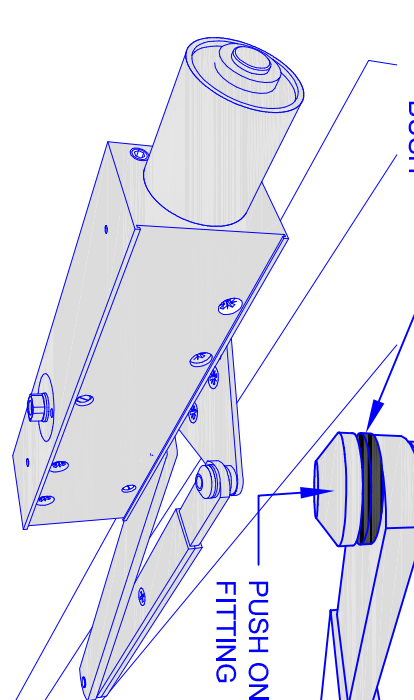

3. Secure the closer arm to the closer body using the arm bolt (rotate the pinion using a 12mm spanner as shown in drawing 4) (use a 10mm ring spanner to ensure this is tight). Then connect the arm to the soffit plate. Insert the plastic bush into the arm, place the arm onto the soffit plate then press the push on fitting firmly onto the soffit plate rivet.

4

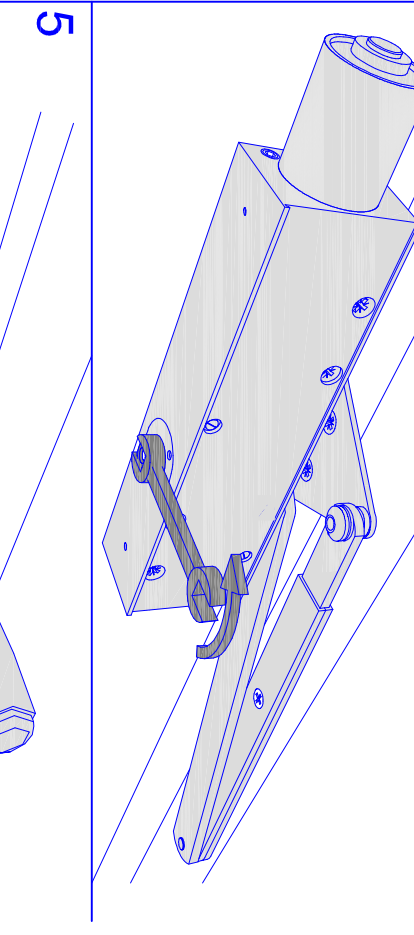

5. When fitted in parallel mode your mode selector screw should be screwed in tight. For all other instructions follow 4/5 and 6 over leaf.

5

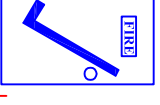
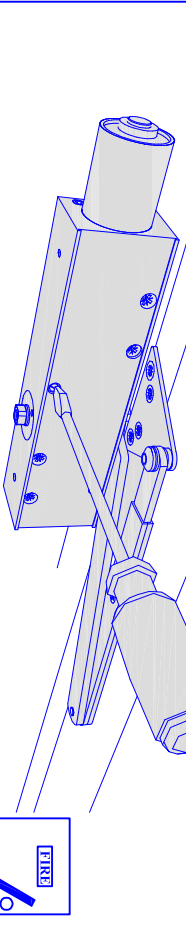



ARROW ARCHITECTURAL
Tything Road
Alcester
B496ES
15

1121-OPR-AE5007	EN1154:1996 + A1:2002/AC:2006
3841113	EN1155:1997 + A1:2002/AC:2006
3841113	

THE CLOSER AND SOFFIT PLATE MUST BE LEVEL (USE A SPIRIT LEVEL) TO ENSURE THEY RUN PARALLEL.

Max leaf width 1100mm, Max kg80, power 4, Max opening 110°

LEFT HAND HINGE

RIGHT HAND HINGE

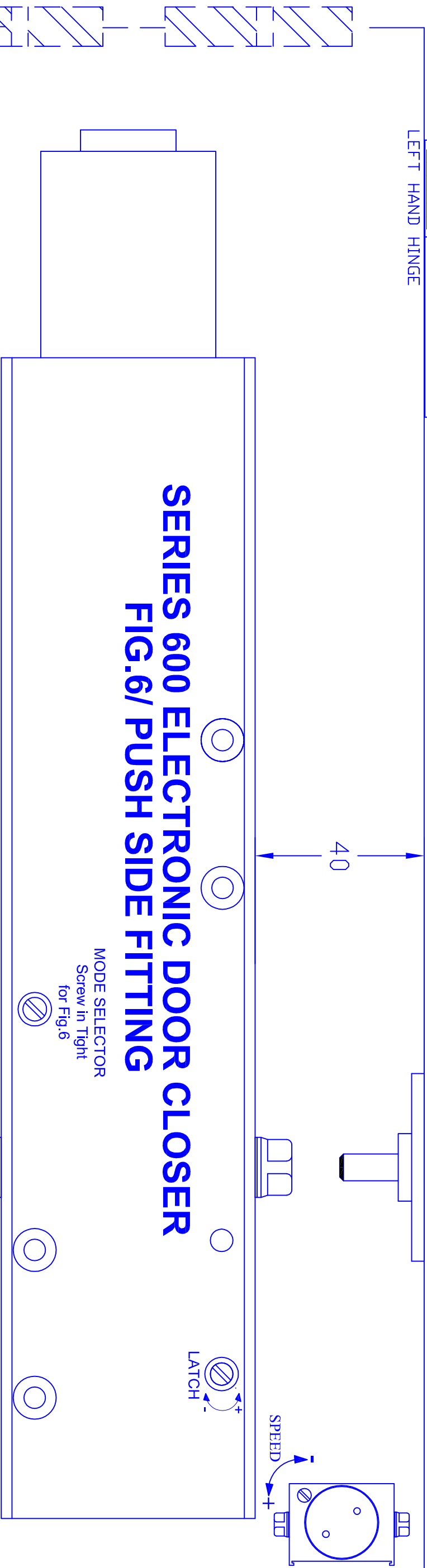

**SERIES 600 ELECTRONIC DOOR CLOSER
FIG.6/ PUSH SIDE FITTING**

MODE SELECTOR
Screw in Tight
for Fig.6

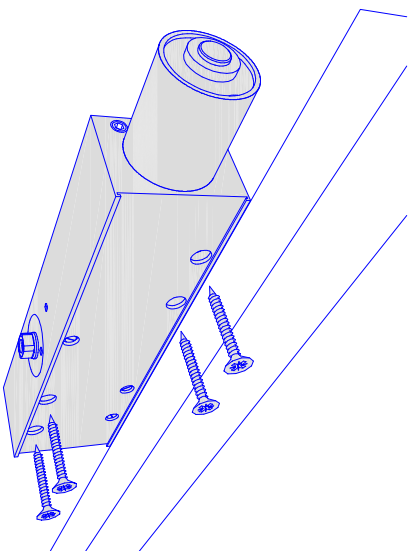
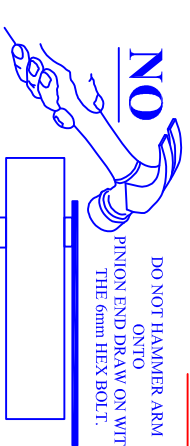

1. Use the template as a guide, drill pilot holes and screw the body to the door with the 2 1/2" wood screws supplied.

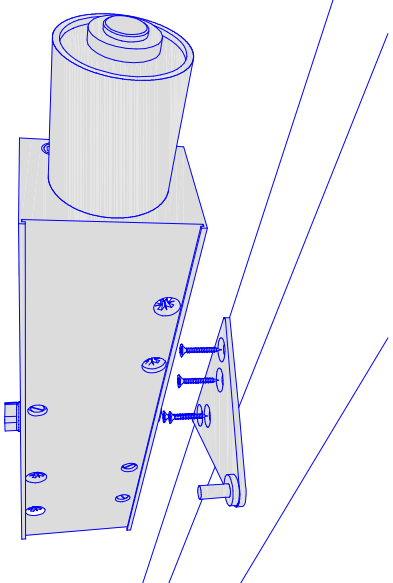

2. Using the template as a guide, drill pilot holes and screw the soffit plate to the under side of the door frame (as shown in the diagram) with the 1" wood screws supplied. The soffit plate must be against the door face.

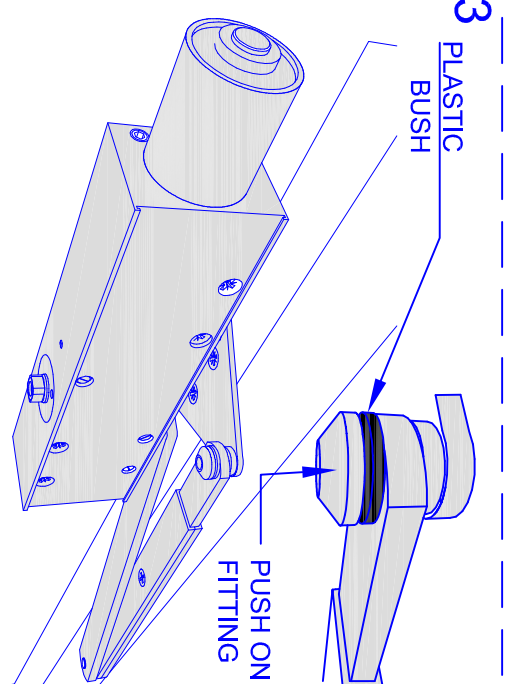

3. Secure the closer arm to the closer body using the arm bolt (rotate the pinion using a 12mm spanner as shown in drawing 4) (use a 10mm ring spanner to ensure this is tight). Then connect the arm to the soffit plate. Insert the plastic bush into the arm, place the arm onto the soffit plate then press the push on fitting firmly onto the soffit plate rivet.

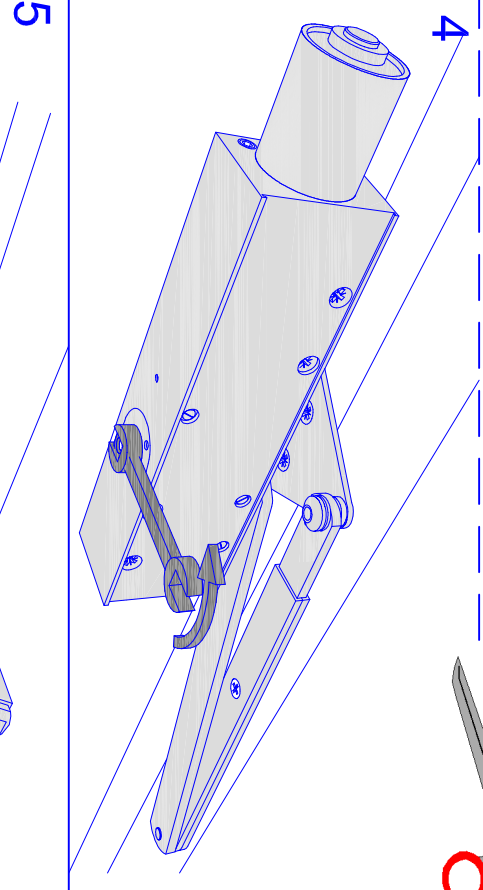

4. When fitted in parallel mode your mode selector screw should be screwed in tight. For all other instructions follow 4/5 and 6 over leaf.

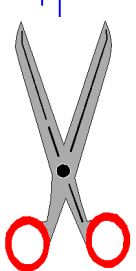
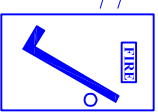
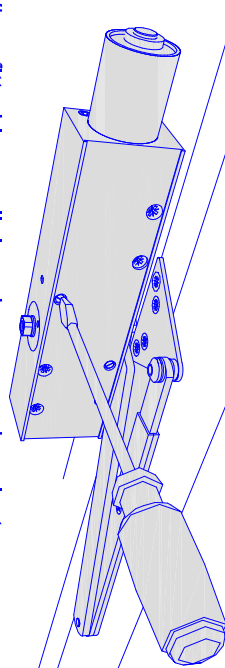

SWING FREE(REGULAR FIG.1)

After switching on the 24vdc supply, open the door any were passed 75° to the required position. The door will then operate as if there were no closer fitted.It may be opened or closed freely with no resistance. In the event of the electric supply being interrupted, the door will close from whatever position it was in.



SWING FREE MODE

WHEN FITTING IN SWING FREE, ONLY USE 1 HEX ARM BOLT IN THE POSITION SHOWN MAKING SURE IT IS VERY TIGHT.

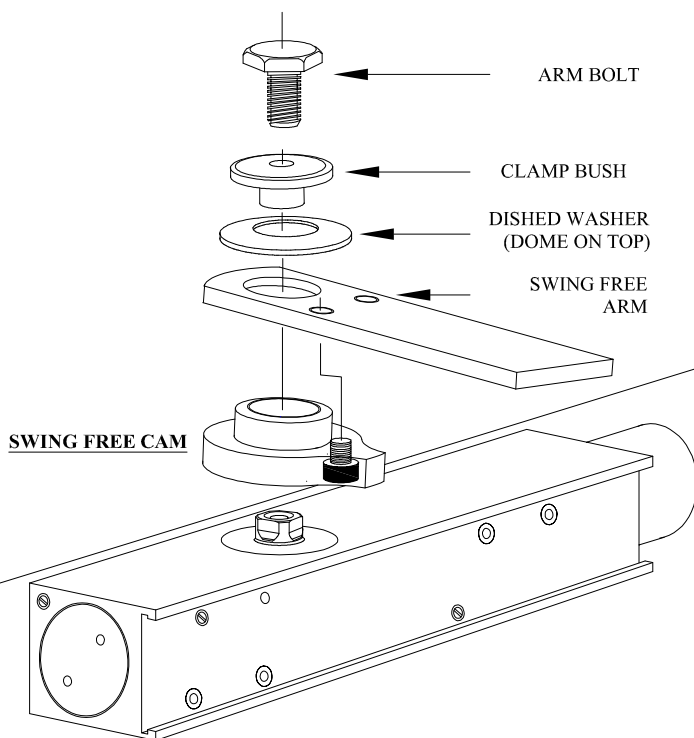
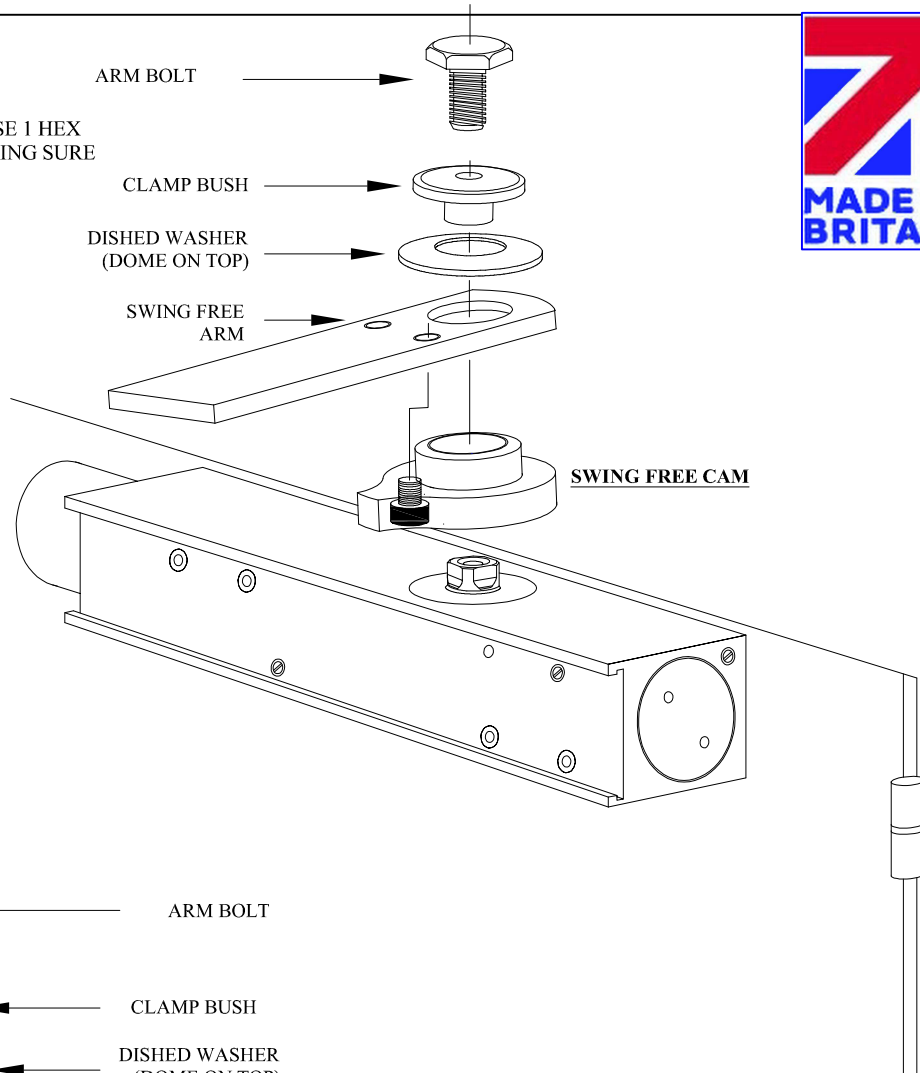

SWING FREE MODE

WHEN FITTING IN SWING FREE, ONLY USE 1 HEX ARM BOLT IN THE POSITION SHOWN MAKING SURE IT IS VERY TIGHT.

PARALLEL ARM APPLICATION FOR PUSH OPEN DOORS CAM SETTINGS FOR SERIES 600 SWING FREE

LEFT HAND HINGE

SWING FREE MODE
WHEN FITTING IN SWING FREE, ONLY USE 1 HEX
ARM BOLT IN THE POSITION SHOWN MAKING SURE
IT IS VERY TIGHT.

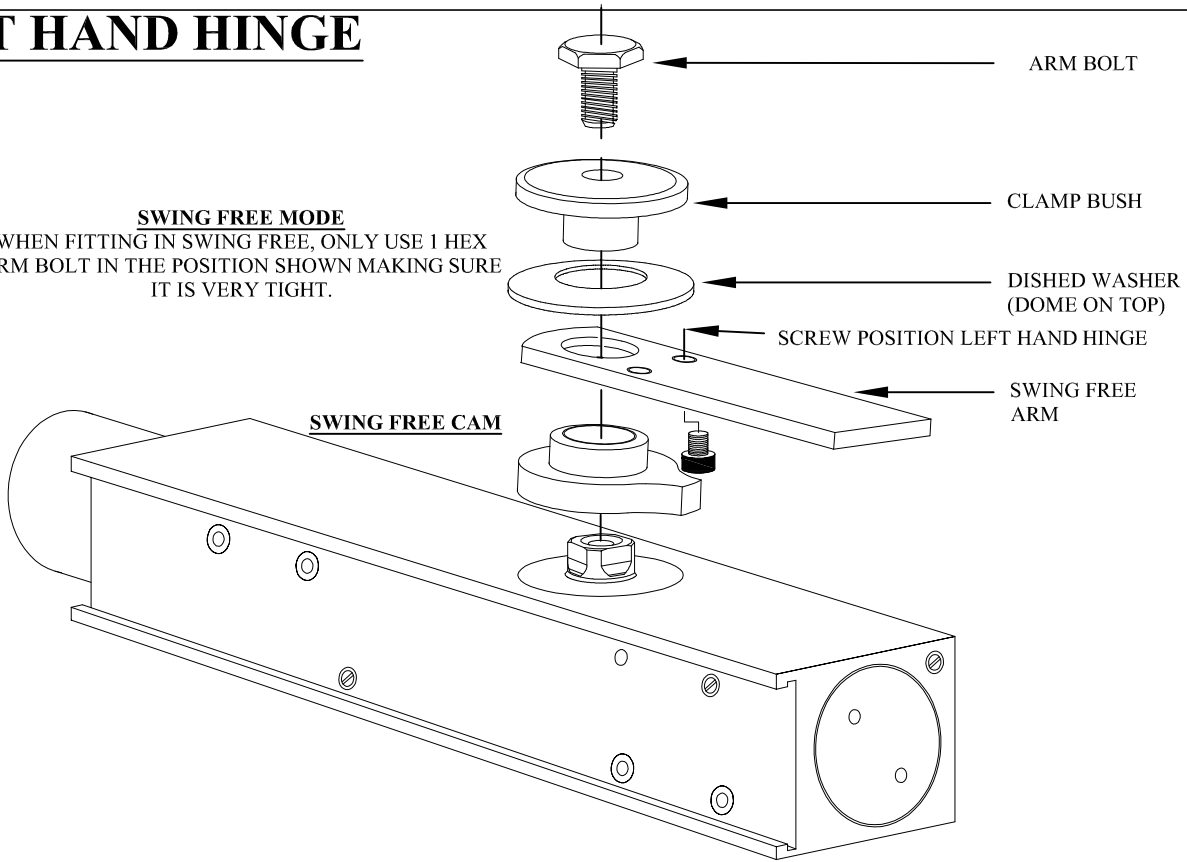

RIGHT HAND HINGE

SWING FREE MODE
WHEN FITTING IN SWING FREE, ONLY USE 1 HEX
ARM BOLT IN THE POSITION SHOWN MAKING SURE
IT IS VERY TIGHT.

