



ARROW ARCHITECTURAL
Tything Road
Alcester
B496ES
04

1121-CPD-ADD0087 EN1154:1996/A1:2002/AC:2006

3811113



APPROVED PRODUCT
CF 497

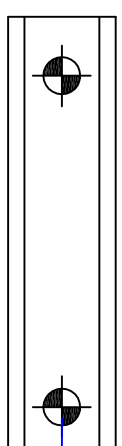

25

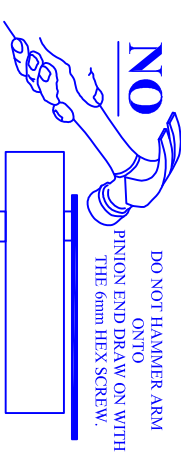

516VP FIG.1

THE CLOSER AND EAR BRACKET MUST BE LEVEL(USE A SPIRIT LEVEL) TO ENSURE THEY RUN PARALLEL.

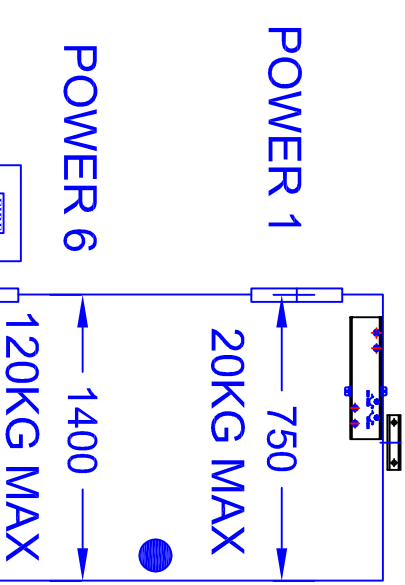
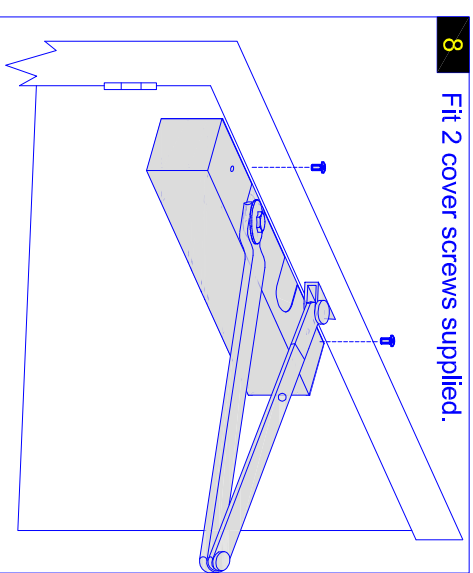
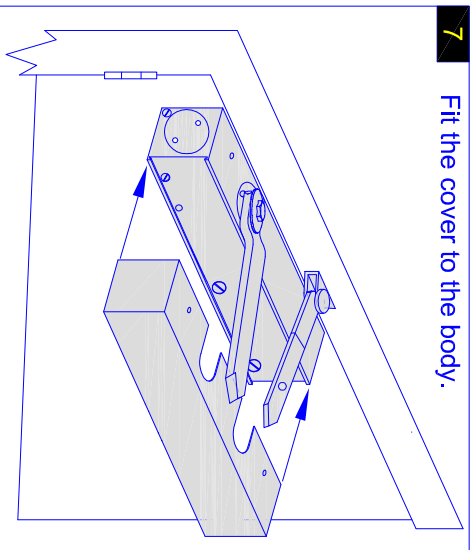
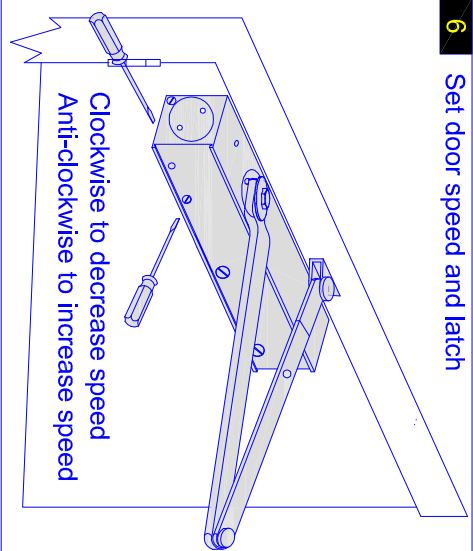
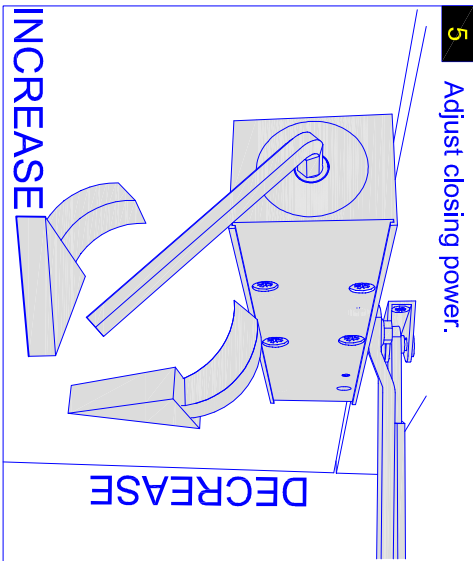
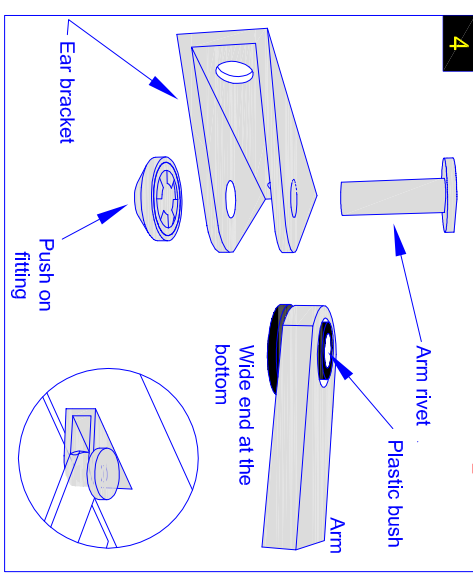
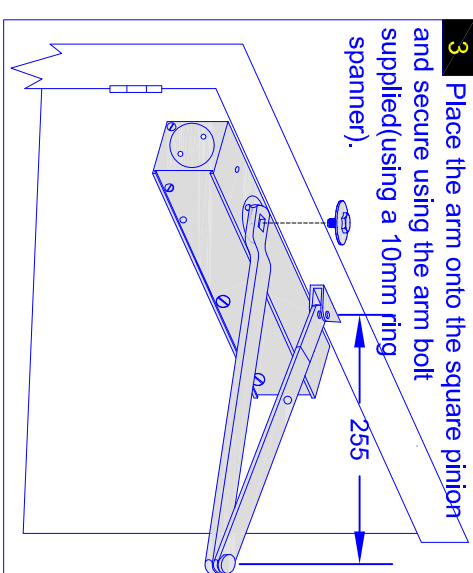
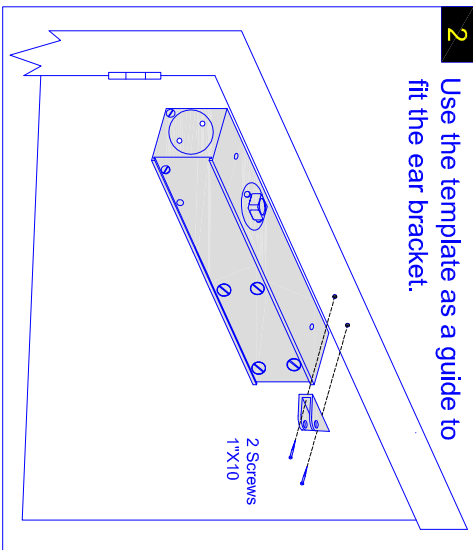
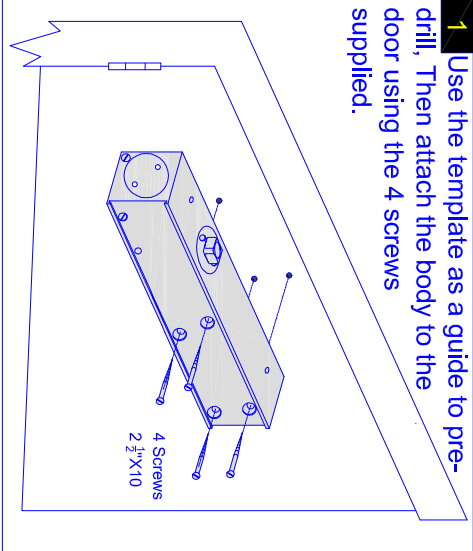
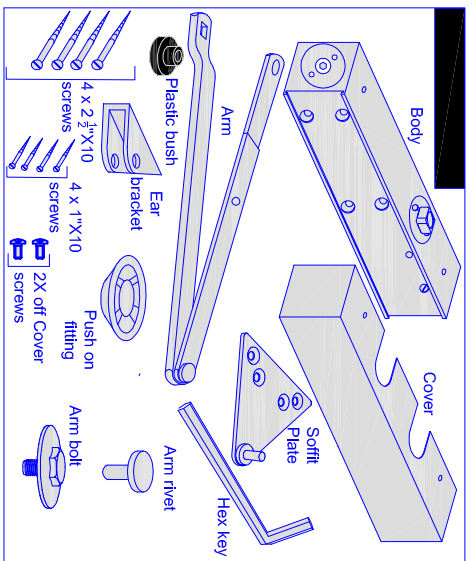
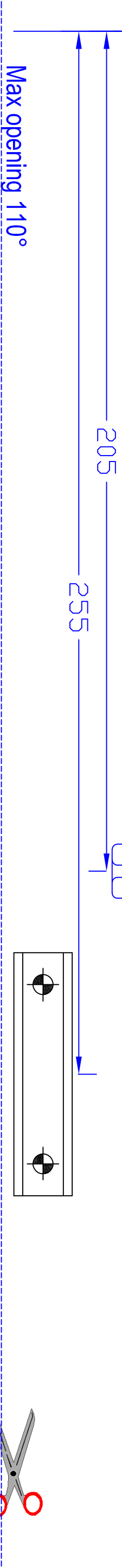

Periodically apply light oil to the arm knuckle joint and check all screws and the pinion bolt are tight.
D.O.P download available at www.arrow-architectural.com

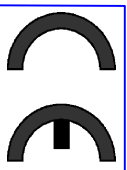

ARROW ARCHITECTURAL
Tything Road
Alcester
B496ES 04



APPROVED PRODUCT
CF 497

Max leaf width 1250mm, Max kg 100, power 5, Max opening 150°

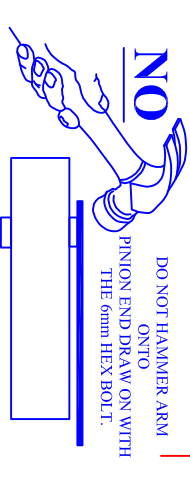

LEFT HAND HINGE

230

40

LATCH

SPEED

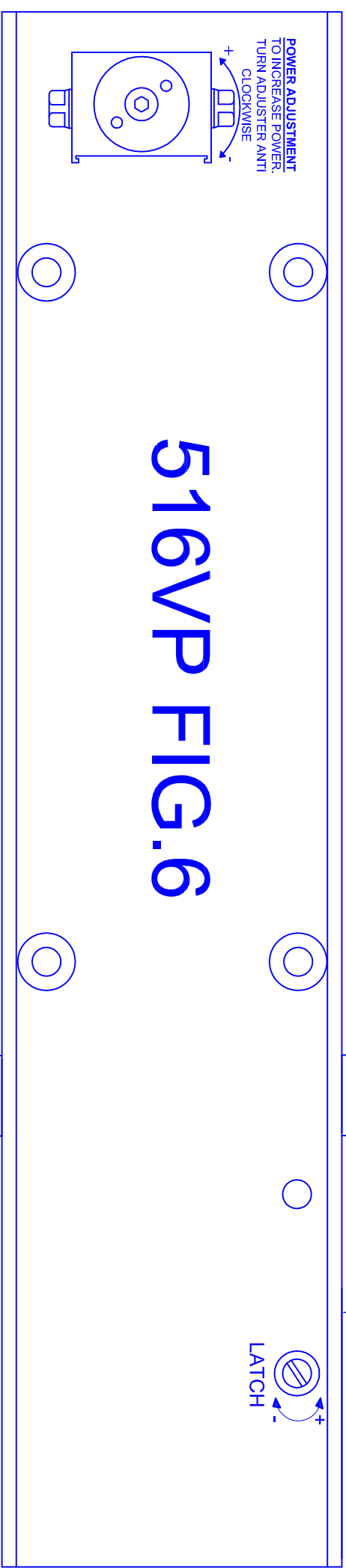

THE CLOSER AND SOFFIT PLATE MUST BE LEVEL(USE A SPIRIT LEVEL) TO ENSURE THEY RUN PARALLEL.

ENGINE DRAWING

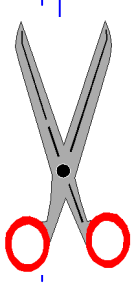

1

2

3

4

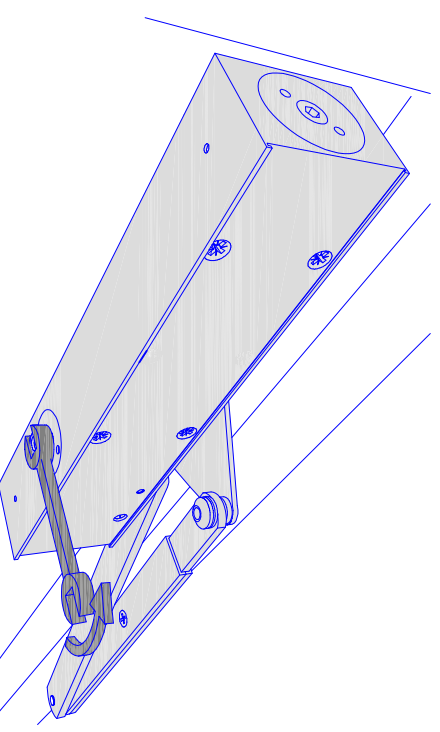
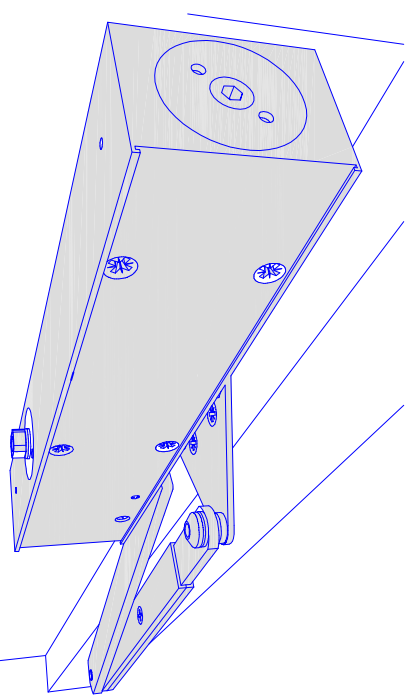
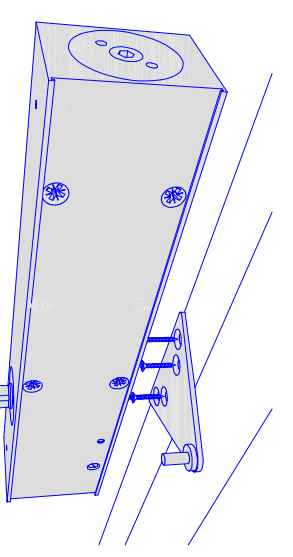
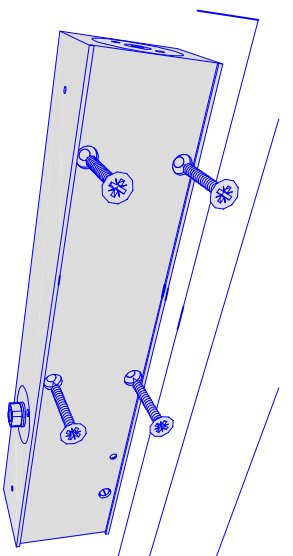

1. Use the template as a guide, drill pilot holes and screw the body to the door with the 2 1/2" wood screws supplied.

2. Use the template as a guide, drill pilot holes and screw the soffit plate to the under side of the door frame (as shown in the diagram) with the 1" wood screws supplied. The soffit plate must be against the door face.

3. Secure the closer arm to the closer body using the arm bolt(rotate the pinion using a 12mm spanner as shown in drawing 4) (use a 10mm ring spanner to ensure this is tight). Then connect the arm to the soffit plate. Insert the plastic bush into the arm, place the arm onto the soffit plate then press the push on fitting firmly onto the soffit plate rivet.

5. For all other instructions follow 5,6,7 and 8 over leaf.

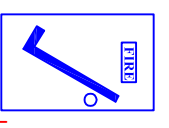

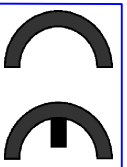

ARROW ARCHITECTURAL
Tything Road
Alcester
B496ES

04
1121-CPD-AD0087
EN1154-1:1996/A1:2002/AC:2006
3831113

THE CLOSER AND EAR BRACKET MUST BE LEVEL (USE A SPIRIT LEVEL) TO ENSURE THEY RUN PARALLEL.

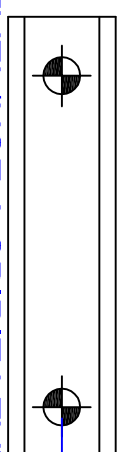

25

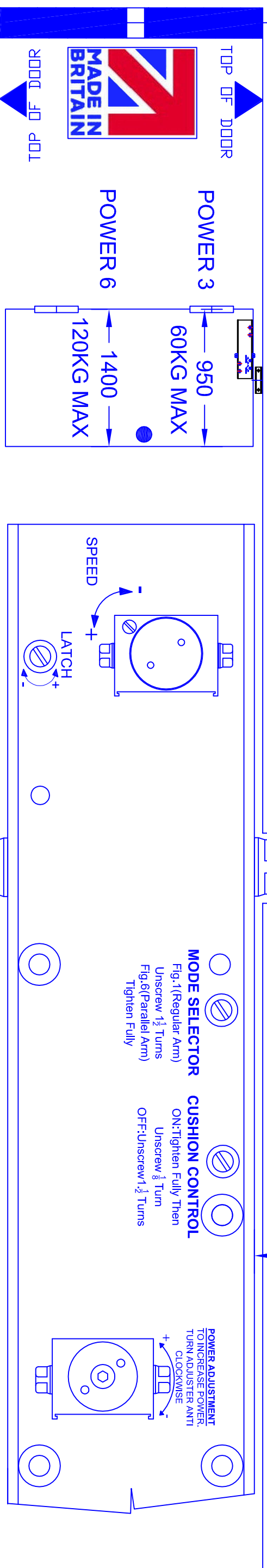
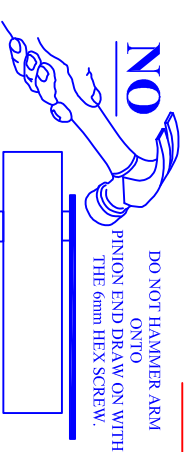

Max opening 110°

516VP+BC FIG.1

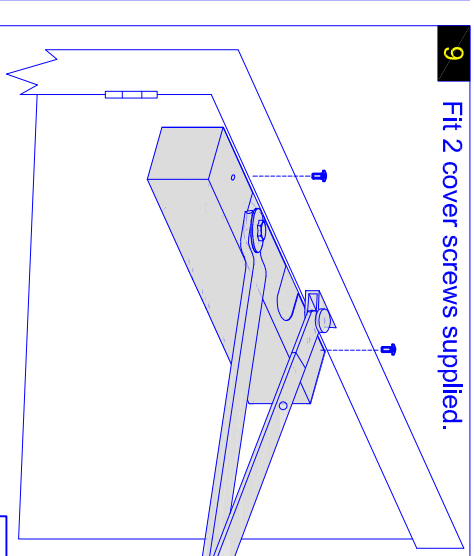
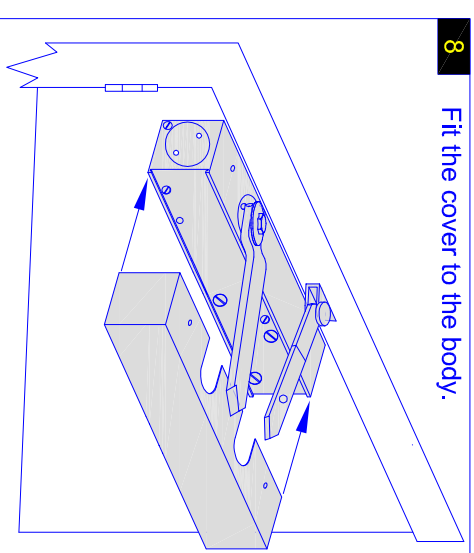
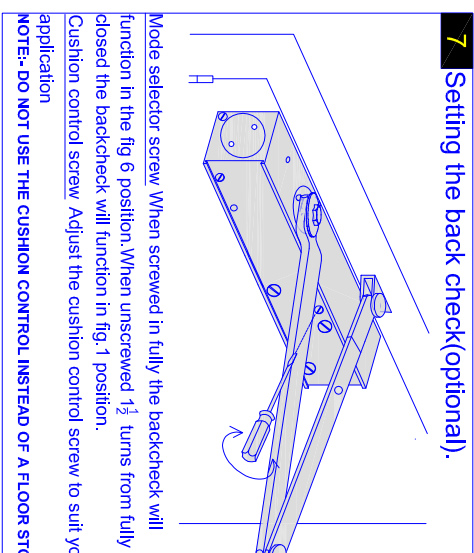
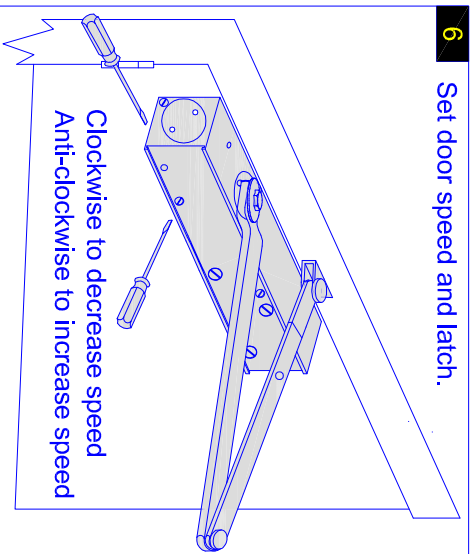
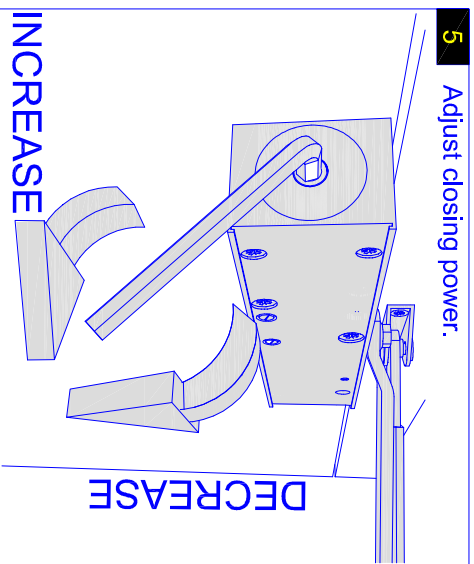
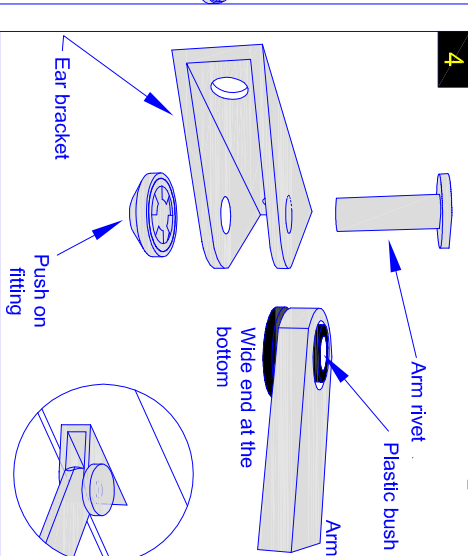
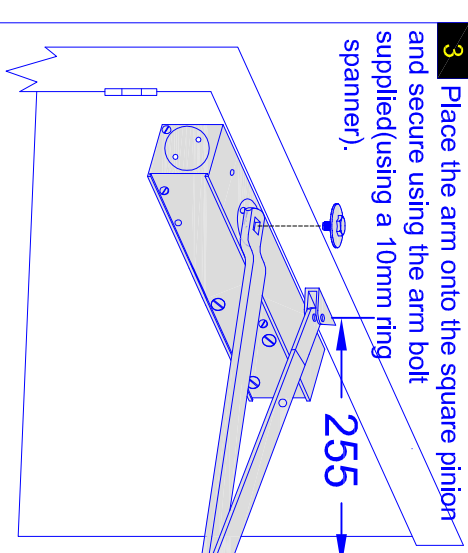
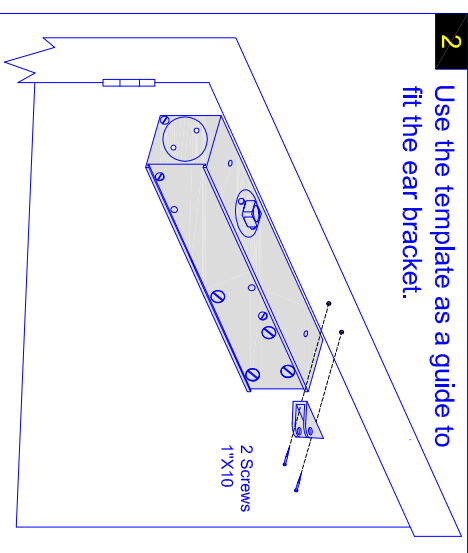
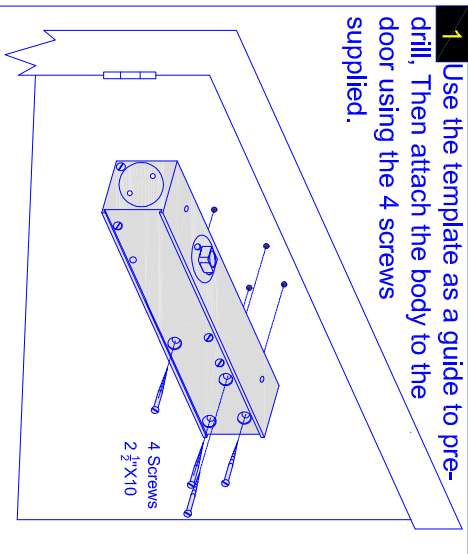
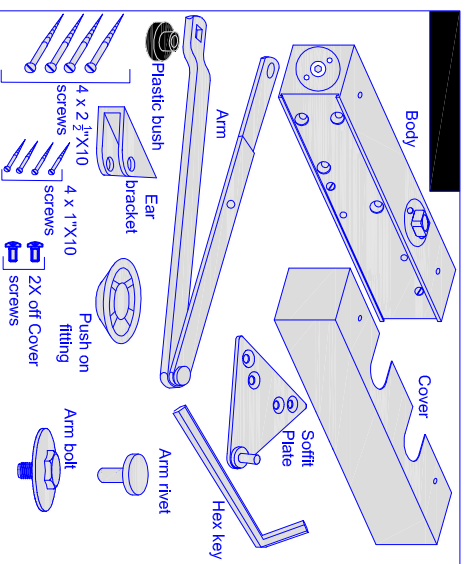

MAINTENANCE

Periodically apply light oil to the arm knuckle joint and check all screws and the pinion bolt are tight
D.O.P download available at www.arrow-architectural.com

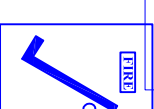

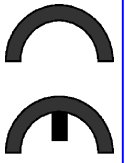

1121-CPD-AD0087	EN1154:1996/A1:2002/AC:2006
38	31113

Max leaf width 1250mm, Max kg 100, power 5, Max opening 150°

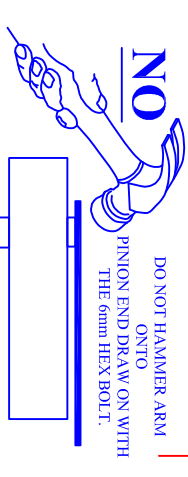

LEFT HAND HINGE

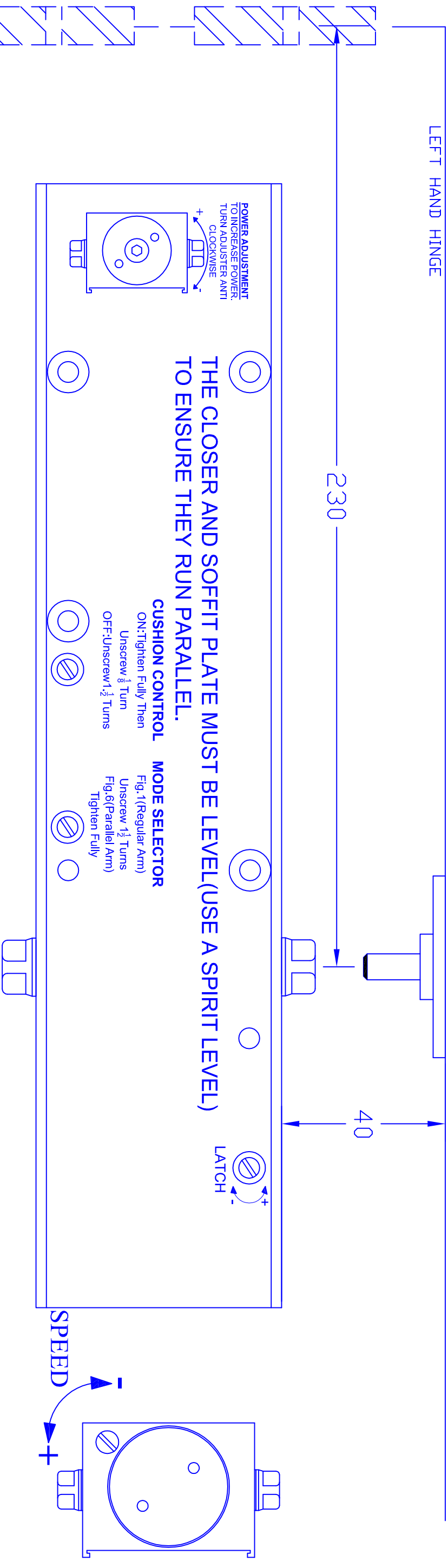

POWER ADJUSTMENT
TO INCREASE POWER, TURN ADJUSTER ANTI CLOCKWISE
TO DECREASE POWER, TURN ADJUSTER CLOCKWISE

CUSHION CONTROL **MODE SELECTOR**

ON: Tighten Fully Then
Unscrew 1/8 Turn
OFF: Unscrew 1 1/2 Turns

Fig:1 (Regular Arm)
Unscrew 1 1/2 Turns
Fig:6 (Parallel Arm)
Tighten Fully

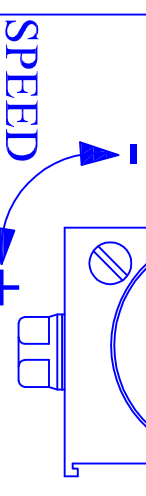

516VP+BC FIG.6

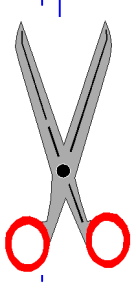

ENGINE DRAWING

1

2

3

4

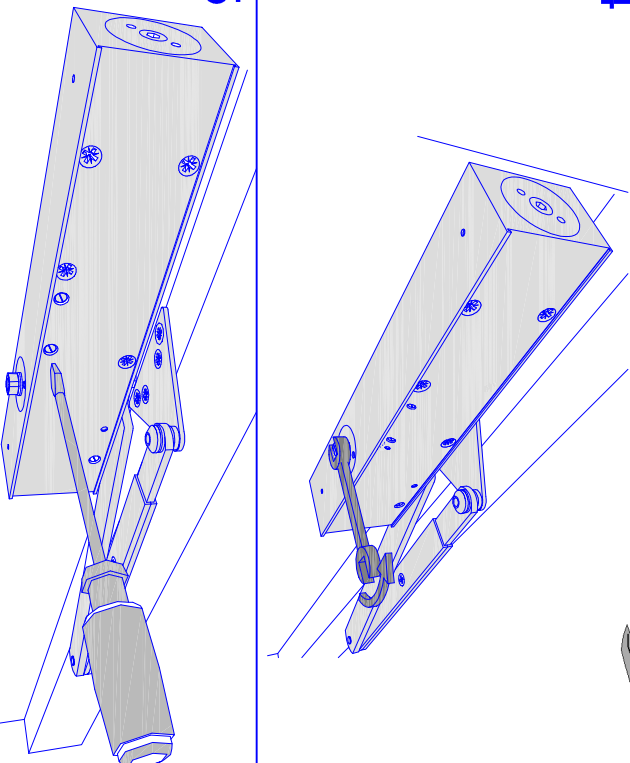
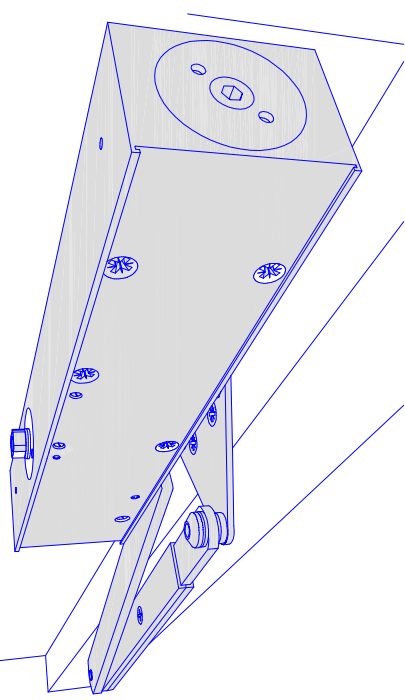
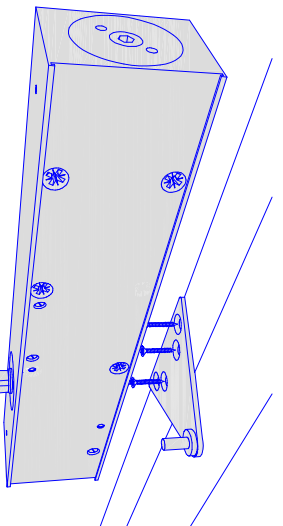
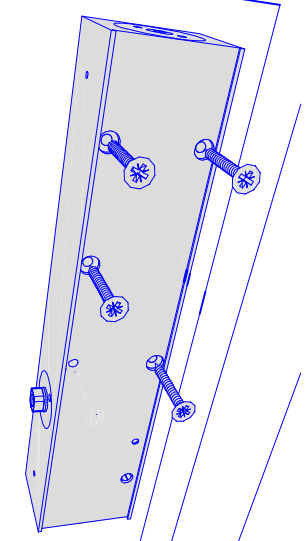

1. Use the template as a guide, drill pilot holes and screw the body to the door with the 2 1/2" wood screws supplied.

2. Use the template as a guide, drill pilot holes and screw the soffit plate to the under side of the door frame (as shown in the diagram) with the 1" wood screws supplied. The soffit plate must be against the door face.

3. Secure the closer arm to the closer body using the arm bolt (rotate the pinion using a 12mm spanner as shown in drawing 4) (use a 10mm ring spanner to ensure this is tight). Then connect the arm to the soffit plate. Insert the plastic bush into the arm, place the arm onto the soffit plate then press the push on fitting firmly onto the soffit plate rivet.

5. When fitting in parallel mode your mode selector screw should be screwed in tight. For all other instructions follow 5, 6, 7, and 9 over leaf.

